

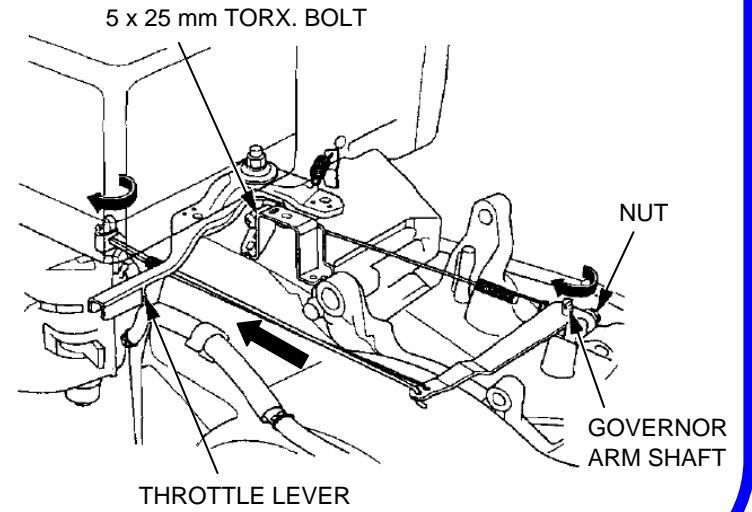

**GOVERNOR**

- ①. Remove the fuel tank.
- ②. Loosen the nut on the governor arm and move the governor arm to fully open the throttle.
- ③. Rotate the governor arm shaft as far as it will go in the same direction the governor arm moved to open the throttle. Tighten the nut on the governor.
- ④. Start the engine and allow it to warm up to normal operating temperature. Determine the point where the engine runs at the standard maximum speed by moving the throttle lever. Then using the special tool, adjust the maximum engine speed by turning the 5 x 25 mm torx. bolt so that the throttle lever cannot be moved past that point. Maximum engine speed: **3,850 ± 150 min<sup>-1</sup> (rpm)**

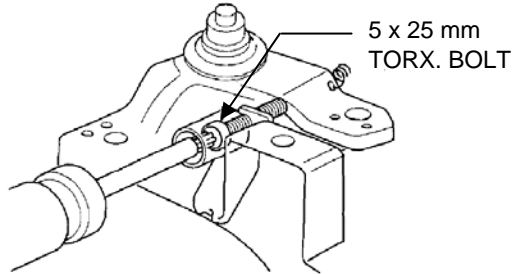

**VALVE CLEARANCE**

NOTE: Valve clearance inspection and adjustment must be performed with the engine cold.

- ①. Remove the cylinder head cover and recoil starter.
- ②. Turn the crankshaft and set the piston at top dead center of the compression stroke (both valves fully closed). The triangle mark on the starter pulley will align with the top hole on the starter cover when the piston is at top dead center of the compression or exhaust stroke.
- ③. Insert a feeler gauge between the rocker arm and valve to measure valve clearance. Valve clearance: **0.15 ± 0.02 mm (IN)**  
**0.20 ± 0.02 mm (EX)**
- ④. If adjustment is necessary, proceed as follows:
  - a. Hold the rocker arm pivot and loosen the rocker arm pivot lock nut.
  - b. Turn the rocker arm pivot to obtain the specified clearance.
  - c. Retighten the rocker arm pivot lock nut while holding the rocker arm pivot. TORQUE: **10 N·m (1.0 kgf·m, 7 lbt·ft)**
  - d. Recheck valve clearance after tightening the rocker arm pivot lock nut.

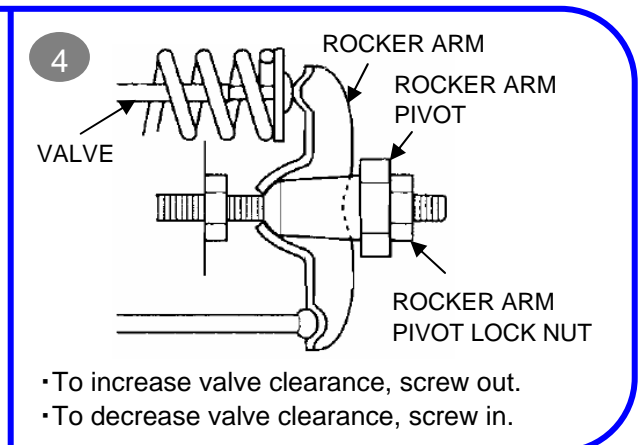
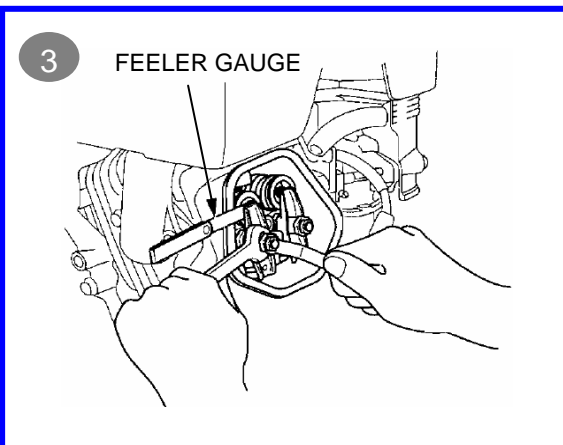
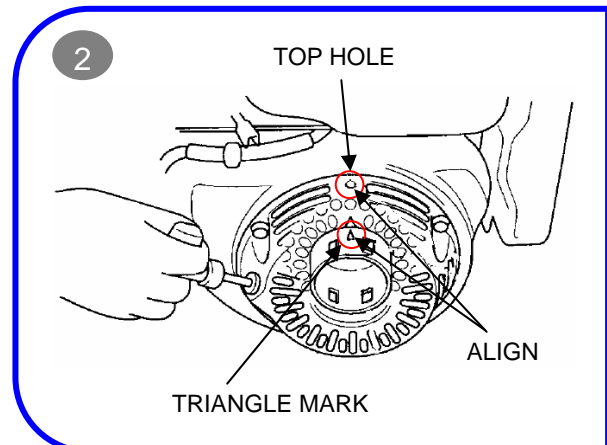
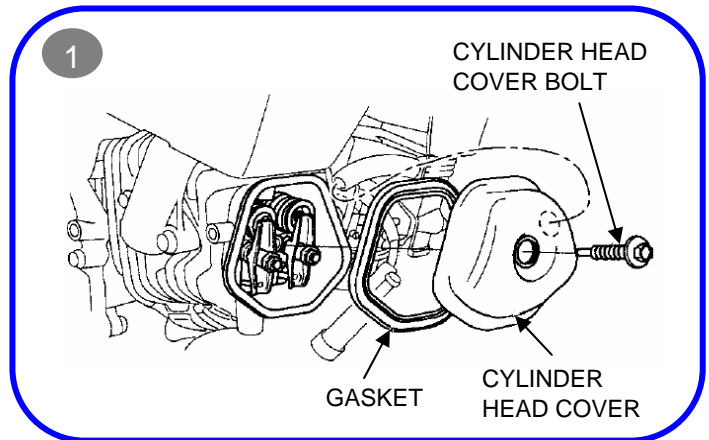

**IGNITION COIL AIR GAP**

- ①. Loosen the ignition coil mounting bolts.
- ②. Insert a feeler gauge of proper thickness between the ignition coil and flywheel.
- ③. Push the ignition coil firmly against the flywheel and tighten the ignition coil mounting bolt. Remove a feeler gauge. Specified gap: **0.4 ± 0.2 mm (0.016 ± 0.008 in)**

NOTE: Avoid the magnet part of the flywheel when adjusting. Adjust the gap equally at both ends of the ignition coil.

